

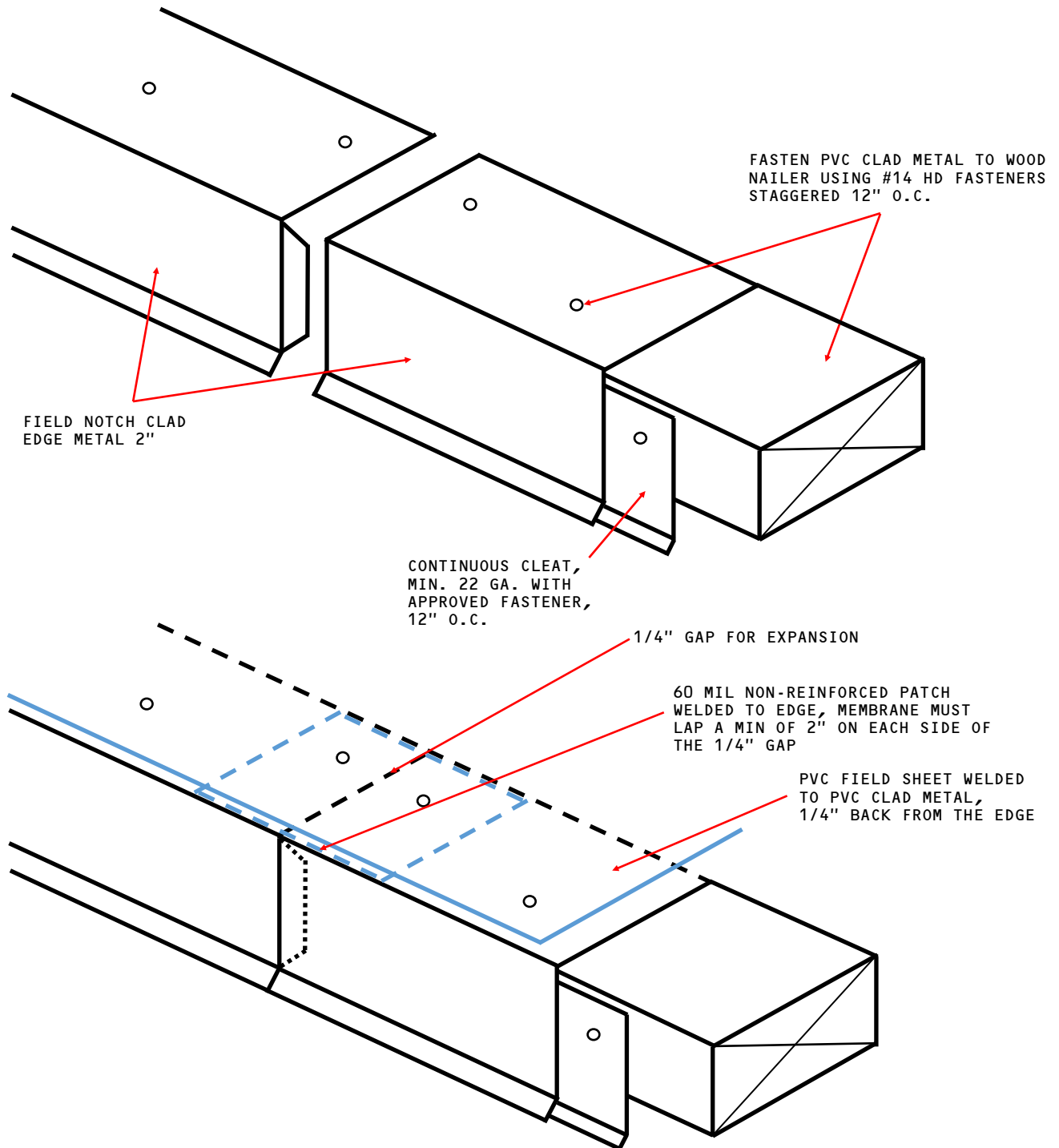

PHOENIX
PRODUCTS™

Overlap Edge Metal Joint Cleated Detail PE-GC 10



NOTES:

1. WOOD NAILER ATTACHED ACCORDING TO LOCAL BUILDING CODE
2. CLEAT REQUIRED ON EDGE METAL WITH FACE GREATER THAN 5"